



Artcoustic^{PT}
LOUDSPEAKERS

CONTENTS

04	The World Of Artcoustic
06	The Pursuit Of Beautiful Sound
08	Powerful Performance
10	Create Your Sound Space
12	What's Your Style?
14	Complete Design Freedom
16	When Sound Meets Design
30	The Ultimate Cinema Experience
40	Products
42	SL Series
52	Spitfire Series
56	Subwoofer Series
60	CPH Series
64	Collection Overview





“With our Danish design roots and dedication to craftsmanship and engineering, we believe that performance and aesthetics go hand in hand.”

THE WORLD OF ARTCOUSTIC

At Artcoustic, we have been designing groundbreaking, world-class loudspeakers since 1998, constantly pushing the limits of convention and challenging the status quo.

Our passion for performance, functionality and design has inspired us to reinvent the conventional loudspeaker with a fresh, modern look. Our roots go back to original Danish loudspeaker design, associated with refined aesthetics and innovative design.

After years of combined design and technical development, we have created a loudspeaker, which looks as good as it sounds, without compromising one to the other.

Our award-winning collection of speakers perform amongst the highest in their class, delivering exceptional efficiency, dynamics and high-quality sound.

As a result, Artcoustic has become a widely-respected loudspeaker brand for the finest music and cinema systems, worldwide.

“We only use the highest quality loudspeaker components, handpicked from Danish suppliers, for the ultimate in sound reproduction.”

THE PURSUIT OF BEAUTIFUL SOUND

To create outstanding loudspeakers, you need incredible components, great workmanship and intricate attention to detail. No detail is overlooked in our process to ensure the most efficient and dynamic sound performance possible.

We use only the highest quality drivers, handpicked from Danish suppliers, for the ultimate in sound reproduction. To achieve this, high-grade copper coils, and bypass capacitors are employed in all our models, and non-inductive resistors are used throughout.

Each unit is painstakingly constructed by hand – no manufacturing line, no robots. Merely a team of dedicated craftsmen putting the speakers together with care, attention, passion and pride.

Each loudspeaker is visually and technically inspected to ensure all products leaving the factory are deserving of the Artcoustic name.

The result is a loudspeaker that is amongst the finest available.





Artcoustic is an industry leader in Sound Pressure Level (SPL) per watt, due to the high sensitivity of our loudspeakers, allowing you to achieve reference level dynamic range with very low amplifier power.

POWERFUL PERFORMANCE

To understand if a speaker can deliver the correct output, we measure the SPL (half space), the amplification needed, and the sensitivity. Speaker sensitivity is a measurement of how well a speaker converts the amplifier power to acoustic energy. In other words, how well the speaker delivers the dynamic range to the listener, for a given amplifier power.

Artcoustic is an industry leader in Sound Pressure Level (SPL) per watt, due to the high sensitivity of our loudspeakers, allowing you to achieve reference dynamic range with very low amplifier power.

Artcoustic gives you an incredibly high output, allowing for the most demanding systems to be designed for. Most Artcoustic array speakers perform fully within, and beyond, the strict Dolby Atmos output requirements (105 dB continuous SPL for speakers and 115dB for subwoofers at the reference listening position).

Artcoustic's line source array technology has allowed us to create a speaker range with an open and transparent sound typically only associated with a Hi-Fi, point source type of speaker. At the same time, using incredibly high sensitivity and sound pressure levels normally only associated with a compression-horn type design.

Artcoustic products can be used for the most demanding systems. Our range delivers the same sound and tonality throughout, so you can always find a speaker that provides the throw distance needed, to accommodate nearly any brief.

“Our design is based around a modular format. All speakers are built to be scalable – from our smallest model to our largest, you can expect the same tonality and quality throughout.”

CREATE YOUR SOUND SPACE

Artcoustic offers a comprehensive and flexible range of loudspeakers to ensure the correct set-up can be specified for the correct application.

We pride ourselves on our bespoke solutions, which enable us to deliver the ultimate sound experience for any interior, small or large, residential or commercial.

Our design is based around a modular format. All speakers are built to be scalable – from our smallest model to our largest, you can expect the same tonality and quality throughout.

Whether you need a music system for your home, are creating a dedicated home cinema or have a commercial space, Artcoustic can provide a solution that fits your requirements.





WHAT'S YOUR STYLE?

Artcoustic provides a canvas like no other, allowing you to create your own unique style. We've taken care of the refined form and quality performance. The look is up to you.

In a few simple steps, you can personalise your loudspeakers to suit your interior.

Choose from a selection of NCS or RAL colours for the cabinet, a matching coloured screen or a digitally printed artwork, chosen from our gallery or your own designs.

All our customisable loudspeakers come in black or white as standard, and include black or white matching screens, which are interchangeable using a magnetic mount.

"In a few simple steps you can personalise your loudspeakers to suit your interior."

COMPLETE DESIGN FREEDOM



CHOOSE A CABINET COLOUR & FINISH

Choose from a selection of NCS/RAL colours. Standard colours come in black or white. Our standard finish is satin.



CHOOSE A SCREEN COLOUR

Our interchangeable screens can be matched to your speaker to create a subtle finish to compliment your interior.



CHOOSE PRINTED ARTWORK

If you want to make a statement with your sound, we can print any digital image, either from our gallery or of your own choice.



“Usually, you have to choose between great sound or great design when it comes to loudspeakers. At Artcoustic we have combined the best of both worlds, so you don’t have to choose between the two.”

WHEN SOUND MEETS DESIGN

Usually, you have to choose between great sound or great design when it comes to loudspeakers. At Artcoustic we have combined the best of both worlds, so you don’t have to choose between the two.

Rooted in Danish design and tradition, each speaker is made to the highest standards by pure workmanship. Our high-end speakers complement every environment, thanks to a fully customisable modular format that emits superior, true, and uniform sound.

Sound has the ability to positively influence our emotions. Artcoustic influences our auditory senses with speakers of exceptional quality, with an uncompromising approach to sound and design.



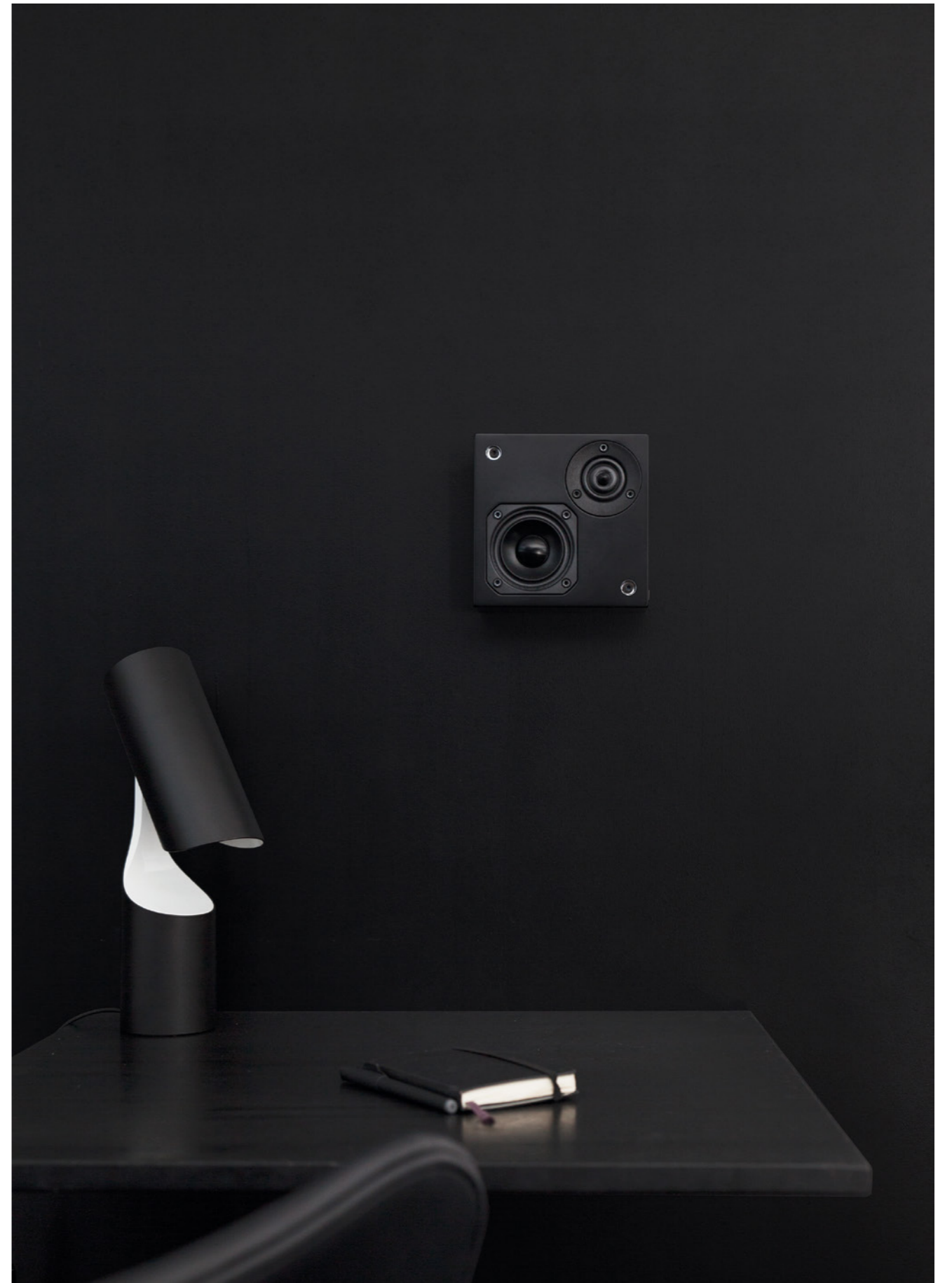

Left: CPH-10 P | Right: SL Evolve 1-1



Featured: SL HSPL Soundbar | SL Evolve 16-8 | Artcoustic Sub 2



Left: SL Multi Soundbar | Right: SL Architect 4-2





Left: SL Evolve 6-3 | Right: SL Evolve 2-1





Left: Sub 2 | Right: SL Elevate



Featured: SL Evolve 3-1 | Sub Z-IWS

“The Spitfire Series is designed for the finest dedicated home cinemas, with different configurations to suit almost any room size.”

THE ULTIMATE CINEMA EXPERIENCE

There are no cheap seats in a well-designed Artcoustic Spitfire Cinema – each seat will be within the highly controlled dispersion pattern – with the line array delivering a more consistent sound pressure level much further down the room than is possible with a point source design.

Artcoustic’s Spitfire Series offers world-class cinema sound without taking up valuable space in the room. For a dedicated cinema, Spitfire offers all aspects of performance, dynamics, output, flexibility and practicality.

The Spitfire Series provides you with the most flexible, powerful, and precise cinema speaker we’ve ever produced.







Left: A6 | Right: A14







PRODUCTS

SL Series

Spitfire Series

Subwoofer Series

CPH Series

Collection Overview

SL SERIES

Artcoustic combines cinema-quality performance with high-end design for everyday living. The range is uniquely designed to be scalable, delivering the ultimate cinematic sound experience, from the smallest snug to the largest living space.

The design of the SL Series has been optimised in a way that allows the loudspeakers to achieve a near perfect response curve, without compromising on any of the existing high-end features including extreme sound pressure levels, sensitivity, extended frequency response, controlled directivity, exceptional speed and transient response.

All arranged within a minimalistic, slimline cabinet.



EVOLVE 1

Operating Range: 100 Hz (-6dB) to 20 kHz
 Sensitivity: 88 dB
 Average Peak SPL: 104 dB
 Max Power: 30 Watt
 Impedance: 8 ohms
 Weight: 1 kg
 Dimensions (mm): H 120 • W 120 • D 98

CUSTOMISATION

Cabinet: RAL/NCS, SL Satin, IP66 (outdoor)
 Screen: Black Metal Grille, IP66 Powder Coated

Standard cabinet colours are black/white

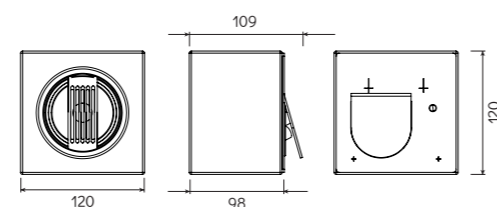

EVOLVE 1-1

Operating Range: 70 Hz (-3 dB) to 40 kHz
 Sensitivity: 89 dB
 Average Peak SPL: 104 dB
 Max Power: 30 Watt
 Impedance: 7 ohms
 Weight: 1.3 kg
 Dimensions (mm): H 150 • W 150 • D 72 / 82

CUSTOMISATION

Cabinet: RAL/NCS, SL Satin
 Screen: RAL/NCS

Standard cabinet/screen colours are black/white

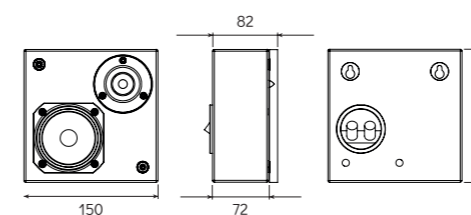

EVOLVE 2-1

Operating Range: 55 Hz (-3 dB) to 40 kHz
 Sensitivity: 91 dB
 Average Peak SPL: 108 dB
 Max Power: 60 Watt
 Impedance: 4 ohms
 Weight: 2.4 kg
 Dimensions (mm): H 200 • W 200 • D 72 / 82

CUSTOMISATION

Cabinet: RAL/NCS, SL Satin
 Screen: RAL/NCS

Standard cabinet/screen colours are black/white

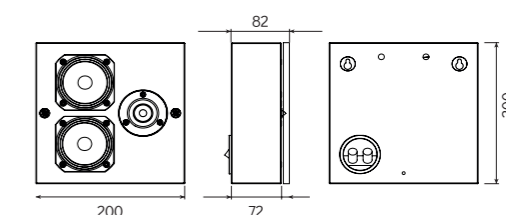



EVOLVE 3-1

Operating Range: 60 Hz (-3 dB) to 40 kHz
 Sensitivity: 94 dB
 Average Peak SPL: 113 dB
 Max Power: 90 Watt
 Impedance: 4 ohms
 Weight: 3.8 kg
 Dimensions (mm): H 370 • W 270 • D 72/82

CUSTOMISATION

Cabinet: RAL/NCS, SL Satin
 Screen: RAL/NCS

Standard cabinet/screen colours are black/white

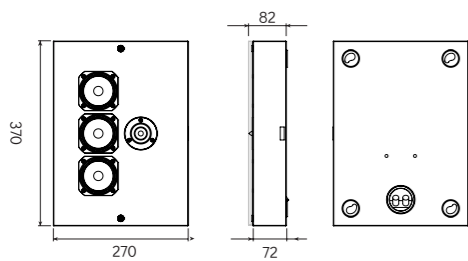

EVOLVE 4-2

Operating Range: 60 Hz (-3 dB) to 40 kHz
 Sensitivity: 96 dB
 Average Peak SPL: 116 dB
 Max Power: 120 Watt
 Impedance: 4 ohms
 Weight: 4.2 kg
 Dimensions (mm): H 370 • W 270 • D 72/82

CUSTOMISATION

Cabinet: RAL/NCS, SL Satin
 Screen: RAL/NCS

Standard cabinet/screen colours are black/white

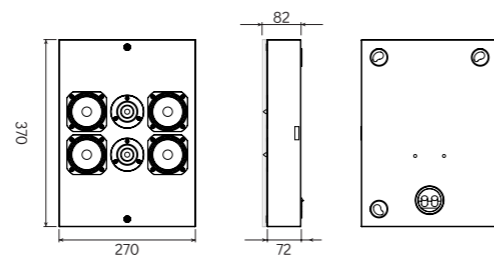

EVOLVE 6-3

Operating Range: 65 Hz (-3 dB) to 40 kHz
 Sensitivity: 98 dB
 Average Peak SPL: 120 dB
 Max Power: 180 Watt
 Impedance: 5 ohms
 Weight: 5.2 kg
 Dimensions (mm): H 370 • W 270 • D 72/82

CUSTOMISATION

Cabinet: RAL/NCS, SL Satin
 Screen: RAL/NCS

Standard cabinet/screen colours are black/white

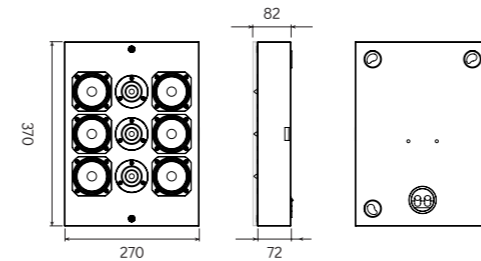

EVOLVE 8-4

Operating Range: 70 Hz (-3 dB) to 40 kHz
 Sensitivity: 99 dB
 Average Peak SPL: 123 dB
 Max Power: 240 Watt
 Impedance: 3.5 ohms
 Weight: 5.8 kg
 Dimensions (mm): H 370 • W 270 • D 72/82

CUSTOMISATION

Cabinet: RAL/NCS, SL Satin
 Screen: RAL/NCS

Standard cabinet/screen colours are black/white

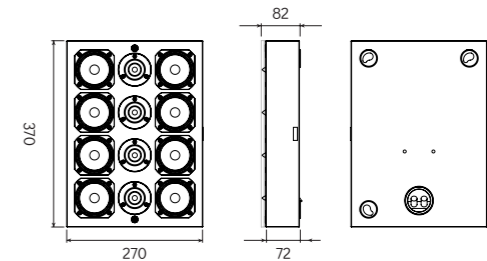



EVOLVE 12-6

Operating Range: 65 Hz (-3 dB) to 40 kHz
 Sensitivity: 101 dB
 Average Peak SPL: 126 dB
 Max Power: 360 Watt
 Impedance: 7 ohms
 Weight: 8.9 kg
 Dimensions (mm): H 550 • W 270 • D 72/85

CUSTOMISATION

Cabinet: RAL/NCS, SL Satin
 Screen: RAL/NCS

Standard cabinet/screen colours are black/white

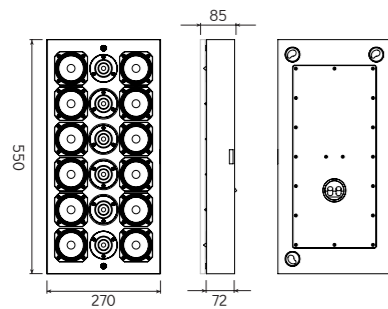

EVOLVE 16-8

Operating Range: 75 Hz (-3 dB) to 40 kHz
 Sensitivity: 103 dB
 Average Peak SPL: 129 dB
 Max Power: 480 Watt
 Impedance: 7 ohms
 Weight: 11.6 kg
 Dimensions (mm): H 716 • W 270 • D 72/85

CUSTOMISATION

Cabinet: RAL/NCS, SL Satin
 Screen: RAL/NCS

Standard cabinet/screen colours are black/white

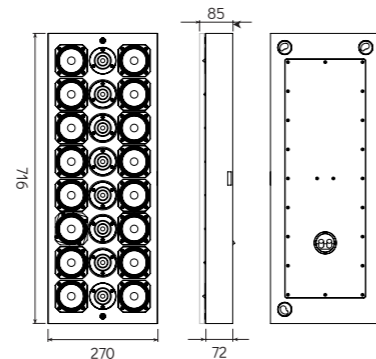

EVOLVE 24-12

Operating Range: 75 Hz (-3 dB) to 40 kHz
 Sensitivity: 107 dB
 Average Peak SPL: 135 dB
 Max Power: 720 Watt
 Impedance: 5 ohms
 Weight: 17 kg
 Dimensions (mm): H 1048 • W 270 • D 72/85

CUSTOMISATION

Cabinet: RAL/NCS, SL Satin
 Screen: RAL/NCS

Standard cabinet/screen colours are black/white

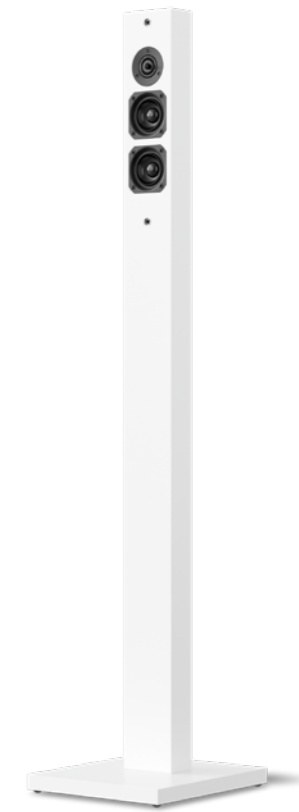
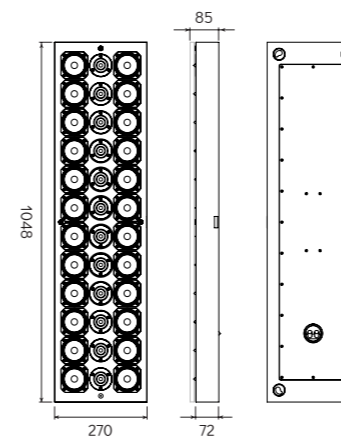

ELEVATE

Operating Range: 55 Hz (-3 dB) to 40 kHz
 Sensitivity: 92 dB
 Average Peak SPL: 111 dB
 Max Power: 60 Watt
 Impedance: 4 ohms
 Weight: 6 kg
 Dimensions (mm): H: 1285 W: 270 D: 300 mm

CUSTOMISATION

Cabinet: RAL/NCS, SL Satin
 Screen: RAL/NCS

Standard cabinet/screen colours are black/white

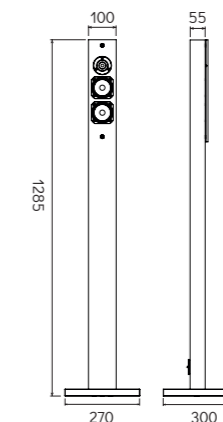

Artcoustic pioneered the first concept of an all-in-one LCR (left, centre and right) soundbar as far back as 1998. The SL Multi version is an evolution of this classic loudspeaker and is available in five standard versions, with the option to go bespoke.

C-1 SOUNDBAR



MULTI SOUNDBAR

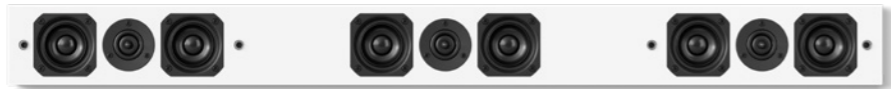

C-1 SOUNDBAR

Operating Range: 70 Hz (-3 dB) to 40 kHz
 Sensitivity: 91 dB
 Average Peak SPL: 108 dB
 Max Power: 60 Watt
 Impedance: 6 ohms
 Weight: 2.7 kg
 Dimensions (mm): H 100 • W 400 • D 61/71

CUSTOMISATION

Cabinet: RAL/NCS, SL Satin
 Screen: RAL/NCS

Standard cabinet/screen colours are black/white

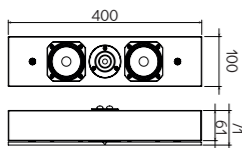

MULTI SOUNDBAR

Operating Range: 70 Hz (-3 dB) to 40 KHz
 Sensitivity: 91/100 dB (LCR/Mono)
 Average Peak SPL: 108/117 dB (LCR/Mono)
 Max Power: 50/180 Watt (LCR/Mono)
 Impedance: 12/4 ohms (LCR/Mono)
 Weight: 5 • 6 • 7 • 8 • 10 kg
 Dimensions (mm): H 100 • W (see below) • D 61/71

CUSTOMISATION

Cabinet: RAL/NCS, SL Satin
 Screen: RAL/NCS

Standard cabinet/screen colours are black/white

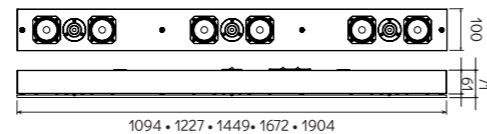

C-2/STEREO SOUNDBAR

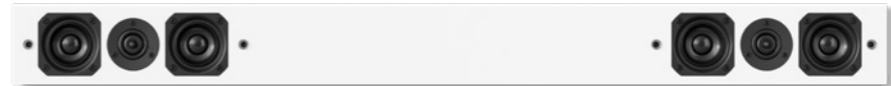

HSPL SOUNDBAR



C-2 STEREO SOUNDBAR

Operating Range: 70 Hz (-3 dB) to 40 KHz
 Sensitivity: 97/91 dB (LCR/Mono)
 Average Peak SPL: 114/108 dB (LCR/Mono)
 Max Power: 100/50 Watt (LCR/Mono)
 Impedance: 6/12 ohms (LCR/Mono)
 Weight: 4.5 • 5.5 • 6.5 • 7.5 kg
 Dimensions (mm): H 100 • W (see below) • D 61/71

CUSTOMISATION

Cabinet: RAL/NCS, SL Satin
 Screen: RAL/NCS

Standard cabinet/screen colours are black/white

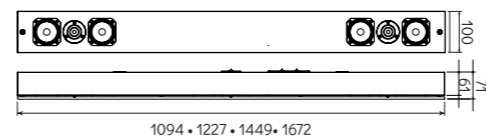

HSPL SOUNDBAR

Operating Range: 70 Hz (-3 dB) to 40 kHz
 Sensitivity: 94/102 dB (LCR/Mono)
 Average Peak SPL: 117/125 dB (LCR/Mono)
 Max Power: 110/300 Watt (LCR/Mono)
 Impedance: 13/4 ohms (LCR/Mono)
 Weight: BESPOKE
 Dimensions (mm): H 100 • W BESPOKE • D 70/80

CUSTOMISATION

Cabinet: RAL/NCS, SL Satin
 Screen: RAL/NCS

Standard cabinet/screen colours are black/white

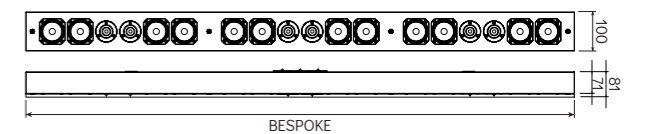

The Architect in-ceiling loudspeakers have been designed and engineered with the same high specifications as all the other Artcoustic models. These loudspeakers have been created to deliver Artcoustic performance from an ultra-thin design, with a clean contemporary aesthetic, but allowing the flexibility to install in-ceiling or in-wall.



ARCHITECT 2-1

Operating Range: 60 Hz (-3 dB) to 40 kHz
 Sensitivity: 93 dB
 Average Peak SPL: 110 dB
 Max Power: 60 Watt
 Impedance: 4 ohms
 Weight: 1.8 kg
 Dimensions (mm): H 240 • W 240 • D 74

CUSTOMISATION

Cabinet: RAL/NCS, SL Satin
 Screen: RAL/NCS

Standard cabinet/screen colours are black/white

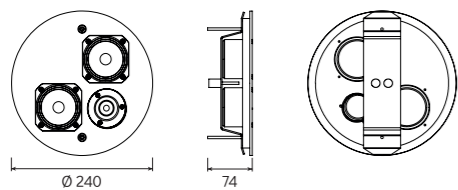

ARCHITECT 4-2

Operating Range: 65 Hz (-3 dB) to 40 kHz
 Sensitivity: 96 dB
 Average Peak SPL: 115 dB
 Max Power: 120 Watt
 Impedance: 4 ohms
 Weight: 3.4 kg
 Dimensions (mm): H 300 • W 300 • D 74

CUSTOMISATION

Cabinet: RAL/NCS, SL Satin
 Screen: RAL/NCS

Standard cabinet/screen colours are black/white

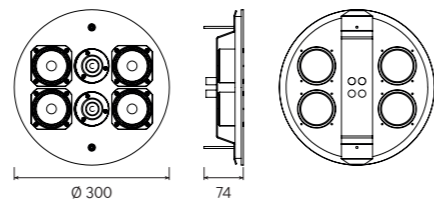

ARCHITECT PAS SPL

Operating Range: 70 Hz (-3 dB) to 40 kHz
 Sensitivity: 94 dB
 Average Peak SPL: 114 dB
 Max Power: 60 Watt
 Impedance: 4 ohms
 Weight: 3.4 kg
 Dimensions (mm): H 300 • W 300 • D 153

CUSTOMISATION

Cabinet: RAL/NCS, SL Satin
 Screen: RAL/NCS

Standard cabinet/screen colours are black/white

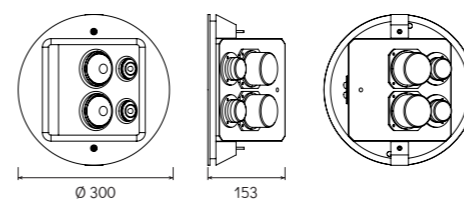

ARCHITECT F1

Operating Range: 40 Hz (-3 dB) to 40 kHz
 Sensitivity: 90 dB
 Average Peak SPL: 105 dB
 Max Power: 100 Watt
 Impedance: 8 ohms
 Weight: 3.5 kg
 Dimensions (mm): H 300 • W 300 • D 86

CUSTOMISATION

Cabinet: RAL/NCS, SL Satin
 Screen: RAL/NCS

Standard cabinet/screen colours are black/white

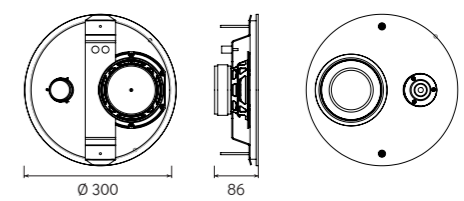

SPITFIRE SERIES

The Spitfire Series is designed for the finest dedicated home cinemas, with different configurations to suit almost any room size.

The Spitfire Series is Artcoustic's dedicated cinema series. Its slimline profile, adjustable vertical and horizontal array, combined with a powerful and articulated performance, makes it the ideal choice for high-end cinema rooms and commercial installations, such as bars and clubs, and in general high SPL installations.

The Spitfire Series has been engineered to produce exceptional sound pressure levels, normally only associated with typical professional audio products.

For the most impressive performance, partner the Spitfire speakers with one of the powerful Artcoustic subwoofers – an ideal setup for small, medium, and large size rooms.

SPITFIRE SERIES



A4

Operating Range: 70 Hz (-6 dB) to 20 kHz
 Sensitivity: 94 dB
 Average Peak SPL: 115 dB
 Max Power: 120 Watt
 Impedance: 8 ohms
 Weight: 3.8 kg
 Dimensions (mm): H 210 • W 280 • D 99
 Cabinet: Black, SL Satin

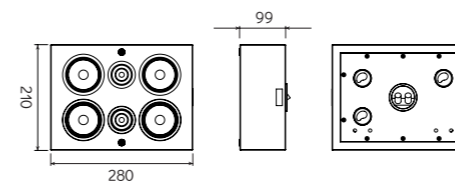

A6

Operating Range: 70 Hz (-6 dB) to 20 kHz
 Sensitivity: 98 dB
 Average Peak SPL: 121 dB
 Max Power: 180 Watt
 Impedance: 11 ohms
 Weight: 5.3 kg
 Dimensions (mm): H 280 • W 280 • D 92
 Cabinet: Black, SL Satin

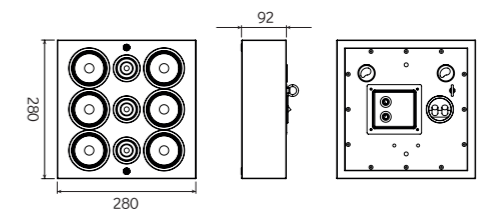

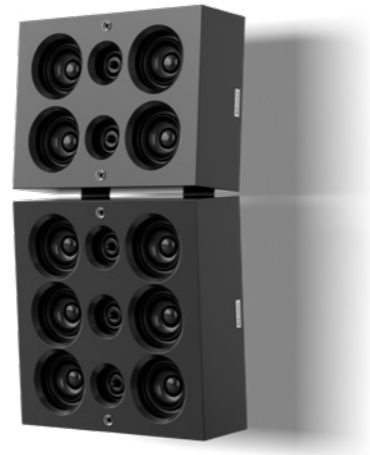

SPITFIRE A10

Operating Range: 70 Hz (-6 dB) to 20 kHz
 Sensitivity: 100 dB
 Average Peak SPL: 128 dB
 Max Power: 300 Watt
 Impedance: 5 ohms
 Weight: 9.1 kg
 Dimensions (mm): H 513 • W 280 • D min. 250/max. 350
 Cabinet: Black, SL Satin

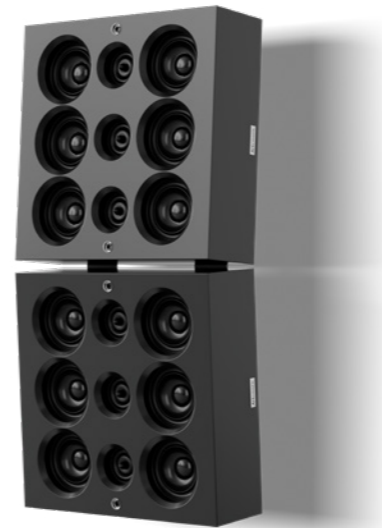
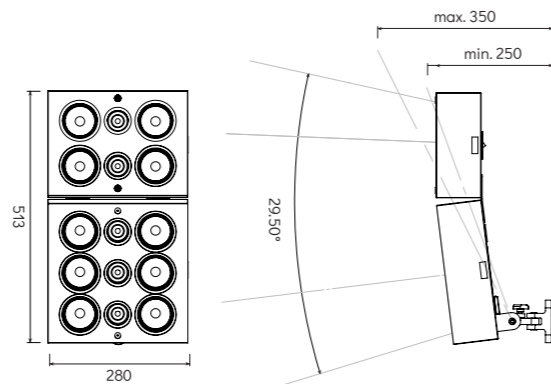

SPITFIRE A12

Operating Range: 70 Hz (-6 dB) to 20 kHz
 Sensitivity: 103 dB
 Average Peak SPL: 127 dB
 Max Power: 360 Watt
 Impedance: 6 ohms
 Weight: 10.6 kg
 Dimensions (mm): H 584 • W 280 • D min. 250/max. 350
 Cabinet: Black, SL Satin

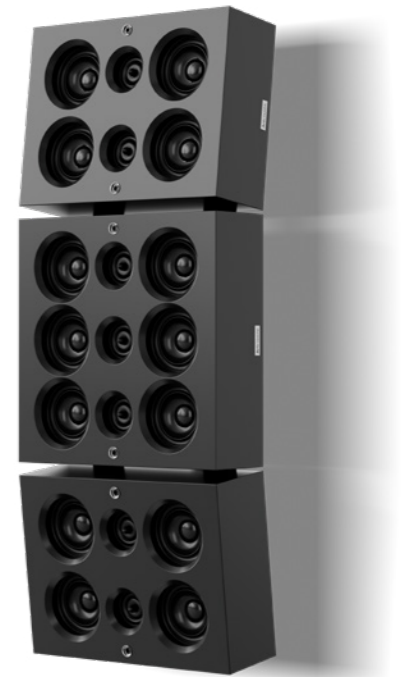
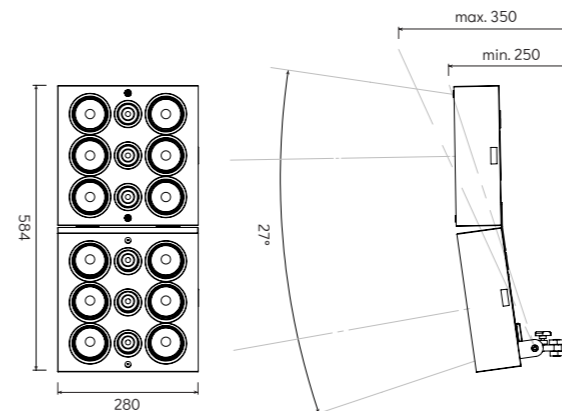

SPITFIRE A14

Operating Range: 70 Hz (-6 dB) to 20 kHz
 Sensitivity: 104 dB
 Average Peak SPL: 130 dB
 Max Power: 420 Watt
 Impedance: 4 ohms
 Weight: 12.9 kg
 Dimensions (mm): H 720 • W 280 • D min. 250/max. 350
 Cabinet: Black, SL Satin

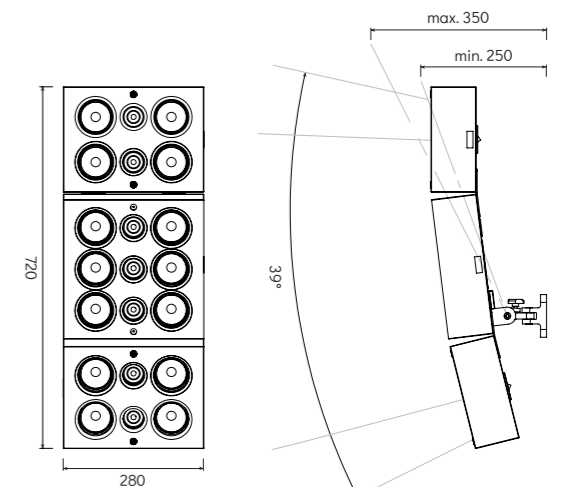

“The Spitfire Series is designed for the finest dedicated home cinemas, with different configurations to suit almost any room size.”

SUBWOOFER SERIES

More than 20 years of subwoofer technology and acoustic evolution has developed into the most advanced and powerful subwoofer series ever produced by Artcoustic.

The Artcoustic Sub Series is a low resonance frequency 4th order band pass design, which ensures powerful and clean bass. Ideal for professional applications such as recording and film studios, dedicated cinemas and fixed installations.

SUBWOOFER SERIES



SUB Z

Operating Range: 35 Hz (-3 dB) to 120 Hz
 Sensitivity: 94 dB
 Average Peak SPL: 110 dB
 Max Power: 160 Watt
 Impedance: 7 ohms
 Weight: 6.1 kg
 Dimensions (mm): H 350 • W 350 • D 208

CUSTOMISATION

Cabinet: RAL/NCS, SL Satin

Standard cabinet colours are black/white

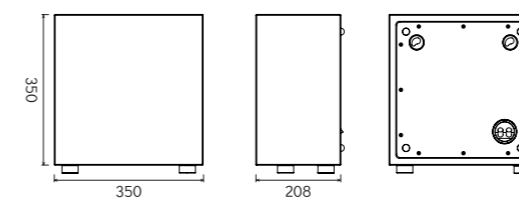

SUB Z-IWS (IN-WALL SUBWOOFER)

Operating Range: 35 Hz (-3 dB) to 120 Hz
 Sensitivity: 94 dB
 Average Peak SPL: 110 dB
 Max Power: 160 Watt
 Impedance: 7 ohms
 Weight: 10 kg
 Dimensions (mm): H 440 • W 440 • D 163

CUSTOMISATION

Cabinet: RAL/NCS, SL Satin

Standard cabinet/baffle colours are black/white

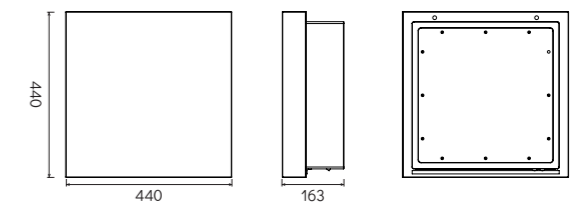



SUB 1

Operating Range: 30 Hz (-3 dB) to 120 Hz
 Sensitivity: 96 dB
 Average Peak SPL: 115 dB
 Max Power: 160 Watt
 Impedance: 7 ohms
 Weight: 17 kg
 Dimensions (mm): H 450 • W 450 • D 233

CUSTOMISATION

Cabinet: RAL/NCS, SL Satin

Standard cabinet colours are black/white

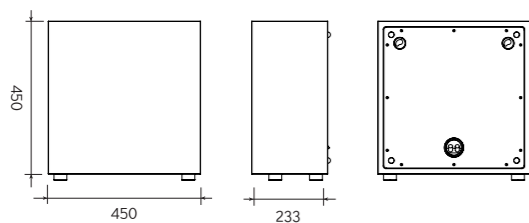

SUB 2

Operating Range: 27 Hz (-3 dB) to 120 Hz
 Sensitivity: 96 dB
 Average Peak SPL: 116 dB
 Max Power: 160 Watt
 Impedance: 7 ohms
 Weight: 18.8 kg
 Dimensions (mm): H 500 • W 500 • D 233

CUSTOMISATION

Cabinet: RAL/NCS, SL Satin

Standard cabinet/baffle colours are black/white

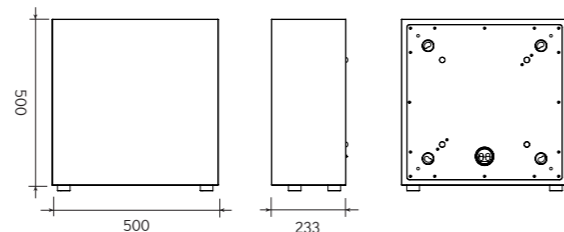

SUB 3

Operating Range: 20 Hz (-3 dB) to 120 Hz
 Sensitivity: 96 dB
 Average Peak SPL: 122 dB
 Max Power: 320 Watt
 Impedance: 14 ohms
 Weight: 28.1 kg
 Dimensions (mm): H 600 • W 600 • D 258

CUSTOMISATION

Cabinet: RAL/NCS, SL Satin

Standard cabinet colours are black/white

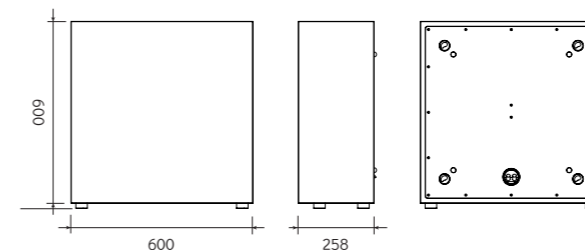

SUB 4

Operating Range: 15 Hz (-3 dB) to 120 Hz
 Sensitivity: 99 dB
 Average Peak SPL: 128 dB
 Max Power: 640 Watt
 Impedance: 8 ohms
 Weight: 51.5 kg
 Dimensions (mm): H 1000 • W 600 • D 258

CUSTOMISATION

Cabinet: RAL/NCS, SL Satin

Standard cabinet/baffle colours are black/white

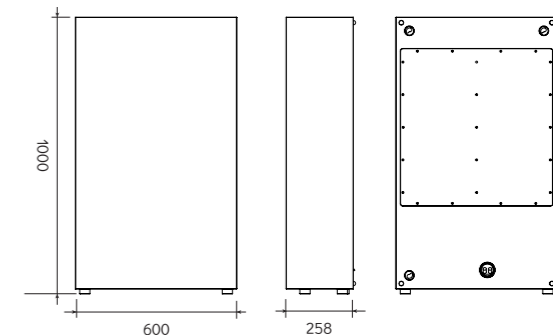

CPH SERIES

Artcoustic's CPH Series delivers quality audio whether you are looking for high-end sound from a single speaker or multiple speakers for a cinema or multiroom set-up.

The CPH Series is designed to be flexible, elegant, customisable and accessible – without compromising on Artcoustic's unique, award-winning sound experience.

CPH SERIES



CPH-10 PASSIVE (MK II)

Operating Range: 35 Hz (-3 dB) 40 kHz
 Sensitivity: 93 dB
 Average Peak SPL: 114 dB
 Max Power: 150 Watt
 Impedance: 8 ohms
 Weight: 8.2 kg
 Dimensions (mm): H 400 • W 300 • D 141/153

CUSTOMISATION

Cabinet: RAL/NCS, SL Satin
 Screen: RAL/NCS

Standard cabinet/screen colours are black/white

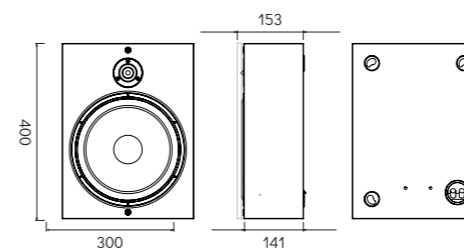

CPH-10 A STEREO

Operating Range: 40 Hz (-3 dB) 20 kHz
 Average Peak SPL: 106 dB
 Max Power: 1x50 Watt and 2x30 Watt
 Impedance: 8 ohms
 Weight: 8.6 kg
 Dimensions (mm): H 400 • W 300 • D 158/170

CUSTOMISATION

Cabinet: RAL/NCS, SL Satin
 Screen: RAL/NCS

Standard cabinet/screen colours are black/white

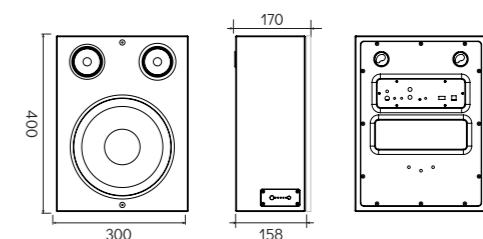



CPH-5

Operating Range: 40 Hz (-3 dB) to 40 kHz
 Sensitivity: 90 dB
 Average Peak SPL: 105 dB
 Max Power: 100 Watt
 Impedance: 8 ohms
 Weight: 4.5 kg
 Dimensions (mm): H 310 • W 230 • D 141/151

CUSTOMISATION

Cabinet: RAL/NCS, SL Satin
 Screen: RAL/NCS

Standard cabinet/screen colours are black/white

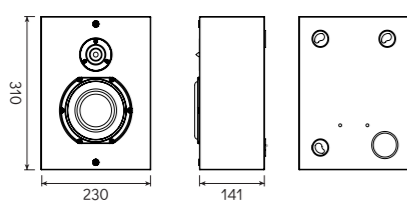

CPH-200 S

Operating Range: 30 Hz to 120 Hz
 Average Peak SPL: 112 dB
 Max Power: 200 Watt
 Impedance: 8 ohms
 Weight: 15 kg
 Dimensions (mm): H 400 • W 400 • D 290

CUSTOMISATION

Cabinet: RAL/NCS, SL Satin
 Screen: RAL/NCS

Standard cabinet/screen colours are black/white

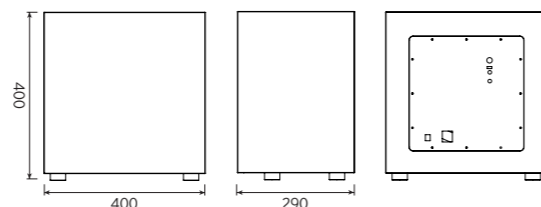

CPH-TRIO

Stereo: 2 x 30 watt 8 ohm
 Sub: 1 x 50 watt 8 ohm
 Full range: 20 Hz - 20 kHz ± 1 dB
 Sub Low-pass filter: 80 Hz 24 dB / oct (fixed)
 Hi-pass filter: 100 Hz & 120 Hz 24 dB/ oct
 Output terminals: Speaker level binding posts
 Connectivity: RCA, Jack 3.5mm, Digital Optical, Bluetooth

Dimensions (mm): H 180 • W 127 • D 48
 Weight: 0.8 kg
 Drivers: Control4 / Crestron

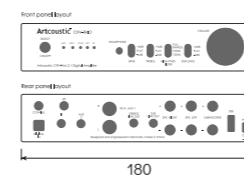

CPH-1000D

Stereo: 8 ohm (450W+450W)
 Bridged: 8 ohm (1000W) – ref manual for specs
 Full range: 20 Hz - 20 KHz ± 0.5 dB
 Sub Low-pass filter: 80 Hz 24 dB/oct 120Hz 24dB/oct
 Output terminals: Speaker level binding posts
 Connectivity: RCA
 Dimensions (mm): H 44 • W 430 • D 48 x 180mm
 Weight: 2.8 kg

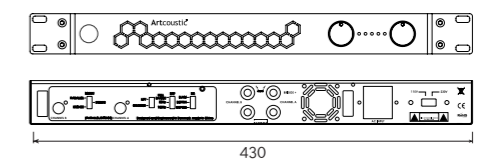

COLLECTION OVERVIEW

Our collection of loudspeakers and subwoofers is made to fit your room size and output needs from very small spaces up to large dedicated cinema rooms, delivering the same tonality throughout. No matter which product you choose, you will get the same sound and quality from your Artcoustic loudspeaker.

SL SERIES

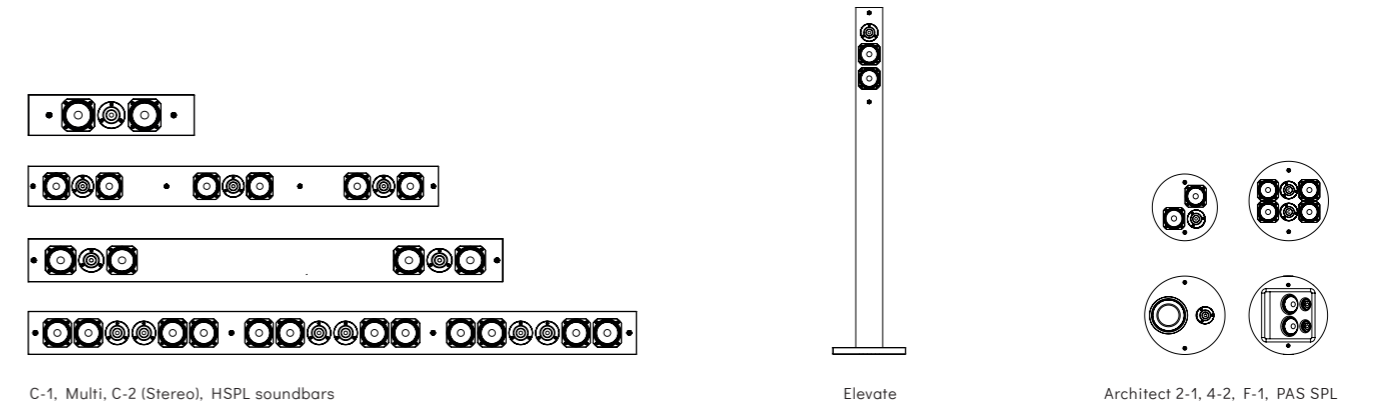
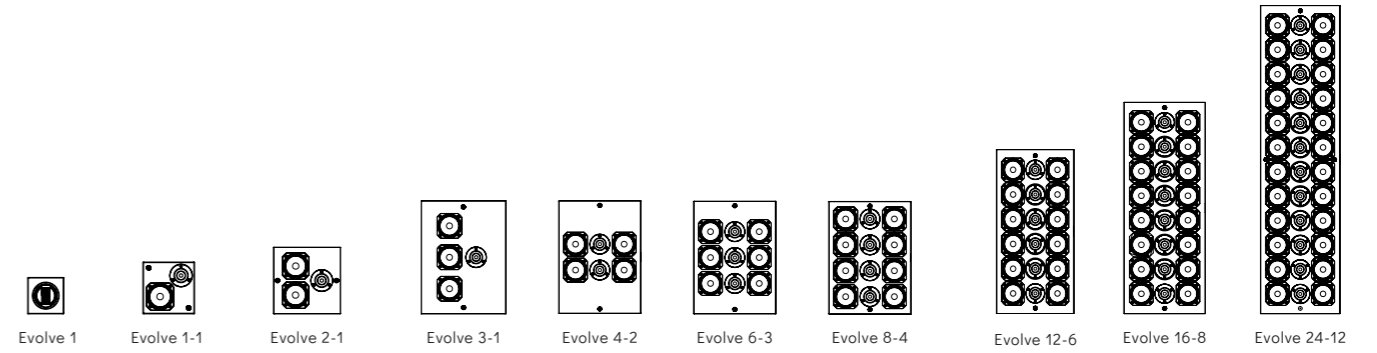

SUBWOOFERS

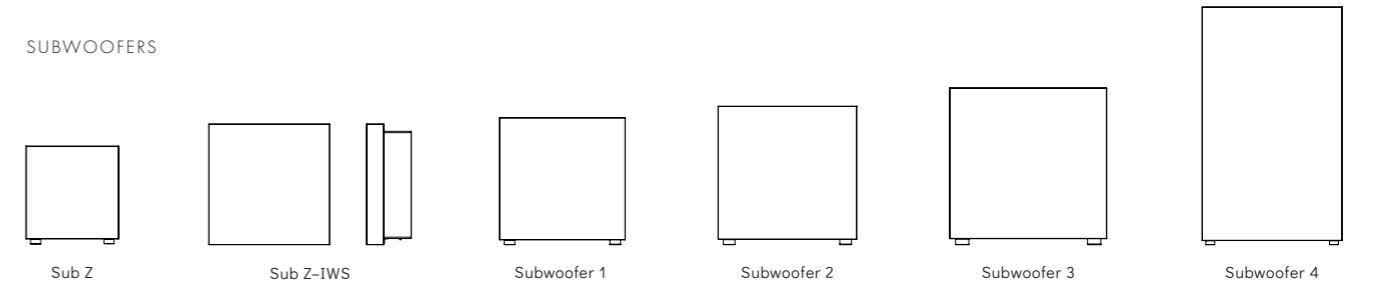

SPITFIRE SERIES

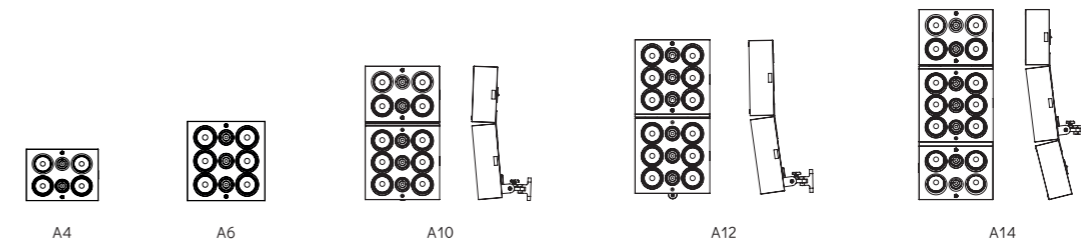

CPH SERIES

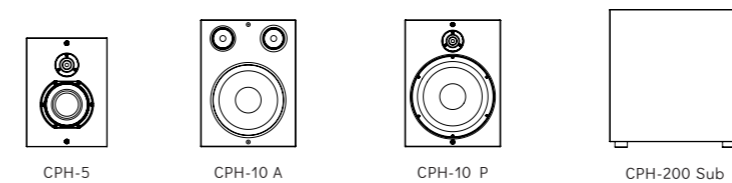

AMPLIFIERS

